

SPECIFICATIONS

MATERIAL	60 DURO TRANSLUCENT SILICONE RUBBER
TEMPERATURE RATING	232°C (450°F)
TENSILE STRENGTH	1275 PSI
ELONGATION	400%
TEAR STRENGTH, DIE B	100 PPI

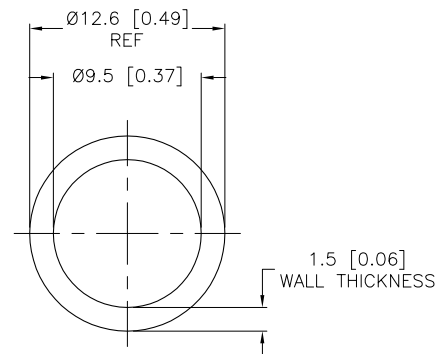

SOURCE DRAWING - FOR REFERENCE ONLY

NOTES:

1. 30 METER SPOOL OF SILICONE TUBING.

RELATED DOCUMENTS		3RD ANGLE PROJECTION		THIS DRAWING IS PROPERTY OF TURCK INC. USE OF THIS DOCUMENT WITHOUT WRITTEN PERMISSION IS PROHIBITED.		TURCK INC High Technology Sensors and Automation Controls 3000 CAMPUS DRIVE MINNEAPOLIS, MN 55441 1-800-544-7769 (763) 553-7300 (763) 553-0708 fax turck.com	
1. 2. 3. 4.				DRFT RWC		DATE 04/16/07	
MATERIAL		ALL DIMENSIONS DISPLAYED ON THIS DRAWING ARE FOR REFERENCE ONLY		DSGN		SCALE 1=5	
SEE SPECIFICATIONS		CONTACT TURCK FOR MORE INFORMATION		UNIT OF MEASUREMENT		DESCRIPTION	
FINISH		MILLIMETER [INCH]		DO NOT SCALE THIS DRAWING		ST ID 3/8-INCH-30M	
SEE SPECIFICATIONS		A9220		IDENTIFICATION NO.		REV	
A DRAWING RELEASE		RWC 04/18/07		FILE: A9220		A	
REV	DESCRIPTION	BY	DATE	ECO NO.	SHEET 1 OF 1		