



### POWER SUPPLY

- AC 100-120 / 220-240V Auto Select Input
- Adjustable Output Voltage
- Efficiency up to 90.4%
- Compact Design, Width only 72.5mm
- Full Power between -10°C and +60°C
- Large International Approval Package
- Precise Output Overvoltage Protection
- 3 Year Warranty

### GENERAL DESCRIPTION

The MiniLine-2 series covers the lower power requirements in the range from 15W to 120W. These units in their rugged plastic housing and large screw terminals are highly efficient, very compact, easy to install and are extremely reliable. Besides the standard 24V power supplies, many other output voltages are also available as well as units rated down to -40°C.

More DIN-Rail power supplies in rugged plastic housings can be found in the MiniLine family which is equipped with quick-connect spring-clamp terminals. These units come in power ranges from 25W to 100W and a variety of output voltages.

The ML120 units are highly immune against electrical disturbances on the mains and provides reliable output power. This offers superior protection for equipment which is connected to the public mains network or is exposed to a critical industrial environment.

Besides the ML120.241, two additional units are available in the ML120 series. The ML120.CLASS2 fulfills the NEC Class 2 requirements and the ML120.244 is a cost optimized regional version for 230V mains voltages.

The supplementary MiniLine-2 redundancy module MLY10.241 allows building of redundant systems or protecting against back-feeding voltages.

### SHORT-FORM DATA

Output voltage	DC 24V	
Adjustment range	24 - 28V	
Output current	5A at 24V 4.3A at 28V	
Output power	120W	
Output ripple	< 50mVpp	20Hz to 20MHz
Input voltage	AC 100-120V / 220-240V Auto-select	
Mains frequency	50-60Hz	±6%
AC Input current	1.82 / 1.07A	at 120 / 230Vac
Power factor	0.62 / 0.54	at 120 / 230Vac
AC Inrush current	typ. 22 / 33A	peak value at 120/ 230Vac 40°C and cold start
DC Input	DC 290V	-25% / +30%
Efficiency	88.8 / 90.4%	at 120 / 230Vac
Losses	15.1 / 12.7W	at 120 / 230Vac
Temperature range	-10°C to +70°C	operational
Derating	3W/°C	+60 to +70°C
Hold-up time	typ. 50 / 50ms	at 120 / 230Vac
Dimensions	72.5x75x103mm	WxHxD
Weight	360g / 0.8lb	

### ORDER NUMBERS

Power Supply	<b>ML120.241</b>	24-28V Standard unit
Accessory	MLY10.241	Redundancy module
	YRM2.DIODE	Redundancy module with alarm contacts

### MARKINGS



Class I Div 2, pend.



Marine, pending

### INDEX



	Page		Page
1. Intended Use .....	3	19. Fulfilled Standards.....	15
2. Installation Requirements.....	3	20. Physical Dimensions and Weight.....	16
3. AC-Input.....	4	21. Accessory.....	17
4. Input Inrush Current .....	5	21.1. Redundancy Modules.....	17
5. Output .....	6	22. Application Notes.....	18
6. Hold-up Time.....	7	22.1. Peak Current Capability .....	18
7. DC-Input.....	7	22.2. Back-feeding Loads .....	18
8. Efficiency and Power Losses.....	8	22.3. Charging of Batteries .....	19
9. Functional Diagram.....	9	22.4. External Input Protection.....	19
10. Front Side and User Elements.....	9	22.5. Parallel Use to Increase Output Power....	19
11. Terminals and Wiring.....	10	22.6. Parallel Use for Redundancy .....	20
12. Lifetime Expectancy and MTBF.....	11	22.7. Inductive and Capacitive Loads.....	20
13. EMC.....	12	22.8. Series Operation .....	21
14. Environment .....	13	22.9. Operation on Two Phases .....	21
15. Protection Features .....	13	22.10. Use in a Tightly Sealed Enclosure .....	21
16. Safety Features.....	14	22.11. Mounting Orientations .....	22
17. Dielectric Strength .....	14		
18. Approvals.....	15		

The information presented in this document is believed to be accurate and reliable and may change without notice.

The housing is patent by PULS (US patent No US D442,923S).

No part of this document may be reproduced or utilized in any form without permission in writing from the publisher.

### TERMINOLOGY AND ABBREVIATIONS

<b>PE and  symbol</b>	PE is the abbreviation for <b>Protective Earth</b> and has the same meaning as the symbol  .
<b>Earth, Ground</b>	This document uses the term "earth" which is the same as the U.S. term "ground".
<b>T.B.D.</b>	To be defined, value or description will follow later.
<b>AC 230V</b>	A figure displayed with the AC or DC before the value represents a nominal voltage with standard tolerances (usually $\pm 15\%$ ) included. E.g.: DC 12V describes a 12V battery disregarding whether it is full (13.7V) or flat (10V)
<b>230Vac</b>	A figure with the unit (Vac) at the end is a momentary figure without any additional tolerances included.
<b>50Hz vs. 60Hz</b>	As long as not otherwise stated, AC 100V and AC 230V parameters are valid at 50Hz and AC 120V parameters are valid at 60Hz mains frequency.
<b>may</b>	A key word indicating flexibility of choice with no implied preference.
<b>shall</b>	A key word indicating a mandatory requirement.
<b>should</b>	A key word indicating flexibility of choice with a strongly preferred implementation.

## 1. INTENDED USE

This device is designed for installation in an enclosure and is intended for the general use such as in industrial control, office, communication, and instrumentation equipment.

Do not use this power supply in equipment, where malfunction may cause severe personal injury or threaten human life.

## 2. INSTALLATION REQUIREMENTS

This device may only be installed and put into operation by qualified personnel.

This device does not contain serviceable parts. The tripping of an internal fuse is caused by an internal defect.

If damage or malfunction should occur during installation or operation, immediately turn power off and send unit to the factory for inspection.

Mount the unit on a DIN-rail so that the output terminals are located on top and input terminal on the bottom. For other mounting orientations see de-rating requirements in this document.

This device is designed for convection cooling and does not require an external fan. Do not obstruct airflow and do not cover ventilation grid (e.g. cable conduits) by more than 15%!

Keep the following installation clearances:

- on top 40mm
- on the bottom 20mm
- Left and right: 0mm (or 15mm in case the adjacent device is a heat source; in example another power supply, ...).

**⚠ WARNING** Risk of electrical shock, fire, personal injury or death.

- Do not use the power supply without proper grounding (Protective Earth). Use the terminal on the input block for earth connection.
- Turn power off before working on the device. Protect against inadvertent re-powering.
- Make sure that the wiring is correct by following all local and national codes.
- Do not modify or repair the unit.
- Do not open the unit as high voltages are present inside.
- Use caution to prevent any foreign objects from entering into the housing.
- Do not use in wet locations or in areas where moisture or condensation can be expected.
- Do not touch during power-on, and immediately after power-off. Hot surface may cause burns.

### Notes for use in hazardous location areas:

The power supply is suitable for use in Class I Division 2 Groups A, B, C, D locations.

### WARNING EXPLOSION HAZARDS!

Substitution of components may impair suitability for this environment. Do not disconnect the unit or operate the voltage adjustment unless power has been switched off or the area is known to be non-hazardous.

A suitable enclosure must be provided for the end product which has a minimum protection of IP54 and fulfils the requirements of the EN 60079-15:2010.

### 3. AC-INPUT

AC input	nom.	AC 100-120V / 220-240V	-15% / +10%, auto-select input
Allowed mains networks		TN/ TT/ IT-mains	
AC input range		85-100Vac	< 45°C continuously allowed > 45°C short term or with output derating according Fig. 3-5
		100-132Vac	continuously allowed (100-120V range)
		187-264Vac	continuously allowed (220-240V range)
		0-85Vac; 132-186Vac	no damage to the unit
		264-300Vac	< 0.5s
Allowed voltage L or N to earth	max.	300Vac	continuously allowed, IEC 62103
Input frequency	nom.	50-60Hz	±6%

		AC 100V	AC 120V	AC 230V	
Input current (rms)	typ.	2.12A	1.82A	1.07A	at 24V, 5A see Fig. 3-3
Power factor <sup>*)</sup>	typ.	0.64	0.62	0.54	at 24V, 5A see Fig. 3-4
Crest factor <sup>**)</sup>	typ.	3.0	3.2	3.6	at 24V, 5A
Start-up delay	typ.	800ms	750ms	35ms	see Fig. 3-2
Rise time	typ.	55ms	55ms	55ms	at 24V, 5A const. current load, 0mF load capacitance, Fig. 3-2
		140ms	140ms	140ms	at 24V, 5A const. current load, 5mF load capacitance
Turn-on overshoot	max.	200mV	200mV	200mV	see Fig. 3-2
Turn-on voltage	typ.	78Vac	78Vac	150Vac	steady-state value, see Fig. 3-1
Shut-down voltage	typ.	65Vac	65Vac	65Vac	steady-state value, see Fig. 3-1

\*) The power factor is the ratio of the true (or real) power to the apparent power in an AC circuit.

\*\*\*) The crest factor is the mathematical ratio of the peak value to RMS value of the input current waveform.

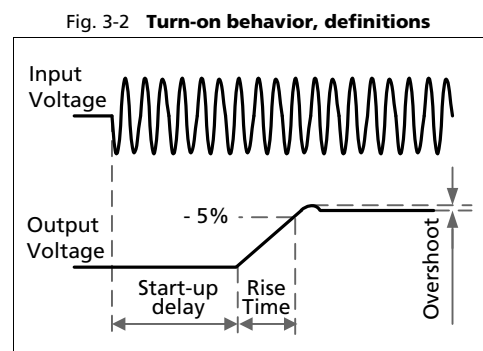
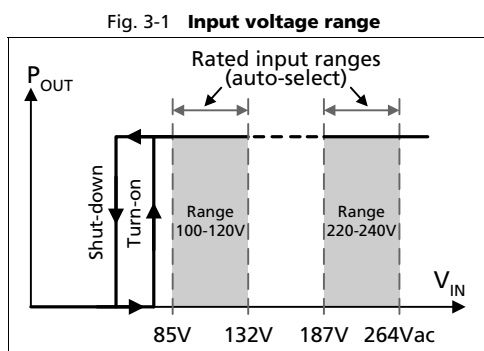

Fig. 3-3 Input current vs. output load at 24V

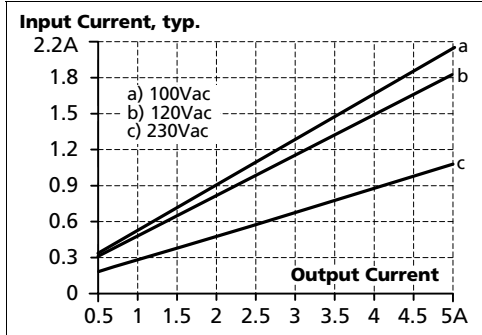

Fig. 3-4 Power factor vs. output load at 24V

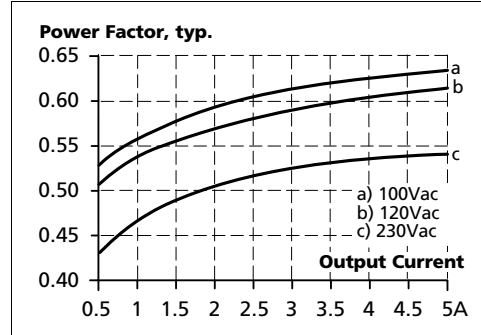
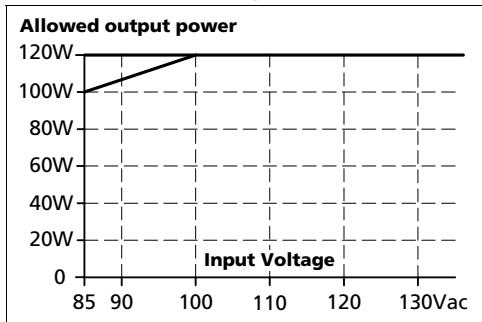

Fig. 3-5 Allowed output power at low input voltages



## 4. INPUT INRUSH CURRENT

A NTC limits the input inrush current after turn-on of the input voltage. The inrush current is input voltage and ambient temperature dependent.

The charging current into EMI suppression capacitors is disregarded in the first microseconds after switch-on.

		AC 100V	AC 120V	AC 230V	
Inrush current	max.	24A <sub>peak</sub>	32A <sub>peak</sub>	45A <sub>peak</sub>	40°C ambient, cold start
	typ.	18A <sub>peak</sub>	22A <sub>peak</sub>	33A <sub>peak</sub>	40°C ambient, cold start
Inrush energy	typ.	0.3A <sup>2</sup> s	0.4A <sup>2</sup> s	1.5A <sup>2</sup> s	40°C ambient, cold start

Fig. 4-1 Input inrush current, typical behavior  
230Vac input, 24V 5A output, 40°C ambient

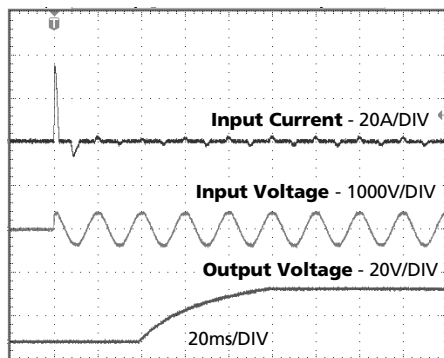
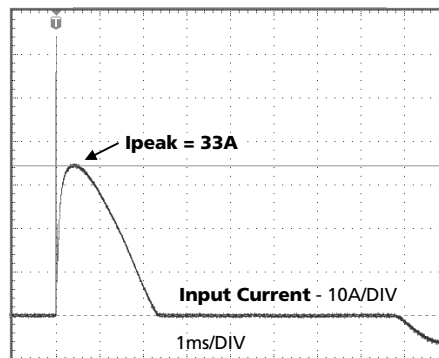

Fig. 4-2 Input inrush current, zoom into first peak  
230Vac input, 24V 5A output, 40°C ambient



### 5. OUTPUT

Output voltage	nom.	24V	
Adjustment range	min.	24-28V	guaranteed
	max.	30V <sup>*)</sup>	at clockwise end position of potentiometer
Factory setting		24.5V	±0.2%, at full load, cold unit
Line regulation	max.	10mV	85-264Vac
Load regulation	max.	100mV	static value, 0A → 5A
Ripple and noise voltage	max.	50mVpp	20Hz to 20MHz, 50Ohm
Output capacitance	typ.	3 000µF	
Output current	nom.	5A	at 24V, see Fig. 5-1
	nom.	4.3A	at 28V, see Fig. 5-1
	peak	25A	The full output voltage cannot be maintained and the output voltage will drip to lower values. Detailed curves can be found in chapter 22.1.
Output power	nom.	120W	
Short-circuit current	min.	7.8A	load impedance 200mOhm, see Fig. 5-1
	max.	9.2A	load impedance 200mOhm, see Fig. 5-1
	max.	8.5A	load impedance <10mOhm, see Fig. 5-1

\*) This is the maximum output voltage which can occur at the clockwise end position of the potentiometer due to tolerances. It is not guaranteed value which can be achieved. The typical value is about 28.6V.

Fig. 5-1 **Output voltage vs. output current, typ.**

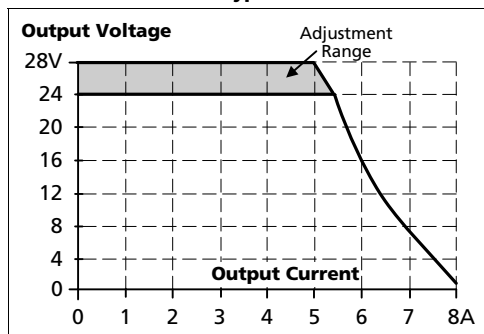

### 6. HOLD-UP TIME

		AC 100V	AC 120V	AC 230V	
Hold-up Time	typ.	71ms	112ms	108ms	at 24V, 2.5A, see Fig. 6-1
	min.	60ms	95ms	92ms	at 24V, 2.5A, see Fig. 6-1
	typ.	29ms	50ms	50ms	at 24V, 5A, see Fig. 6-1
	min.	25ms	43ms	43ms	at 24V, 5A, see Fig. 6-1

Note: At no load, the hold-up time can be up to several seconds. The green DC-on LED is also on during this time

Fig. 6-1 Hold-up time vs. input voltage

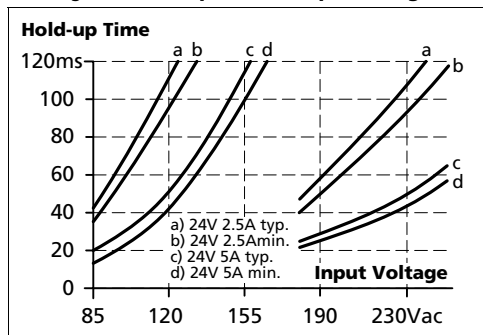
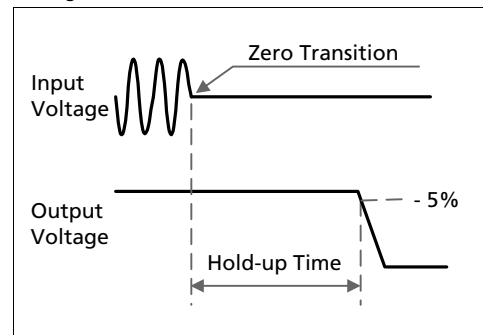

Fig. 6-2 Shut-down behavior, definitions



### 7. DC-INPUT

The power supply can also be supplied from a DC source. Use a battery or similar DC source. For other sources contact PULS.

Connect the + pole to L and the - pole to N. Connect the PE terminal to an earth wire or to the machine ground.

DC input	nom.	DC 290V	-25%/+30%
DC input range	min.	218-377Vdc	continuous operation
Allowed Voltage L/N to Earth	max.	377Vdc	IEC 62103
DC input current	typ.	0.46A	290Vdc, at 24V, 5A
Turn-on voltage	typ.	200Vdc	steady state value
Shut-down voltage	typ.	185Vdc	depending on output load

Fig. 7-1 Wiring for DC Input

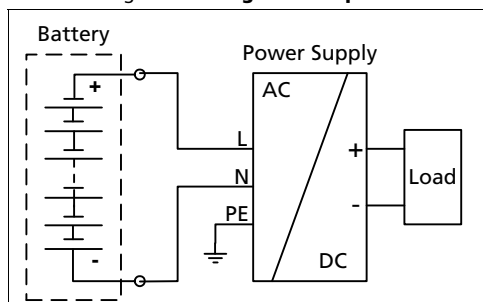

### 8. EFFICIENCY AND POWER LOSSES

		AC 100V	AC 120V	AC 230V	
Efficiency	typ.	88.3%	88.8%	90.4%	at 24V, 5A (full load)
Average efficiency*)		86.4%	86.9%	88.8%	25% at 1.25A, 25% at 2.5A, 25% at 3.75A. 25% at 5A
Power losses	typ.	2.2W	2.6W	1.8W	at 0A
	typ.	8.8W	8.7W	7.0W	at 24V, 2.5A (half load)
	typ.	16.0W	15.1W	12.7W	at 24V, 5A (full load)

\*) The average efficiency is an assumption for a typical application where the power supply is loaded with 25% of the nominal load for 25% of the time, 50% of the nominal load for another 25% of the time, 75% of the nominal load for another 25% of the time and with 100% of the nominal load for the rest of the time.

Fig. 8-1 Efficiency vs. output current at 24V, typ.

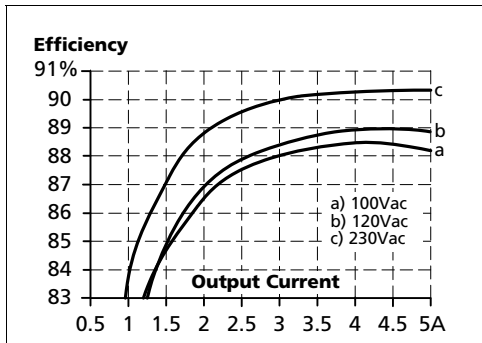

Fig. 8-2 Losses vs. output current at 24V, typ.

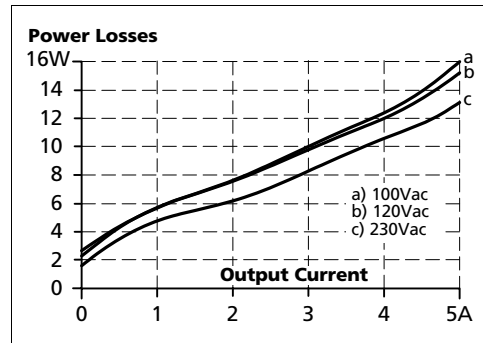

Fig. 8-3 Efficiency vs. input voltage at 24V, 5A, typ.

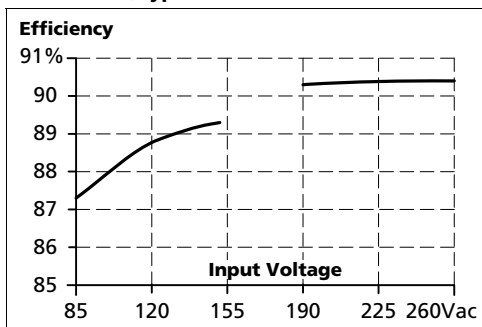
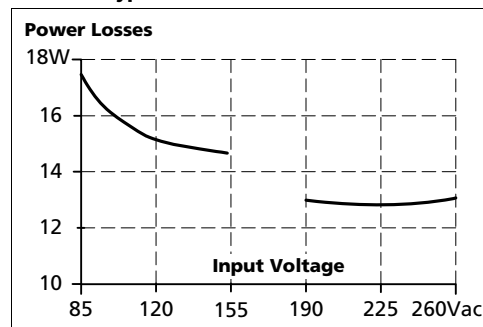
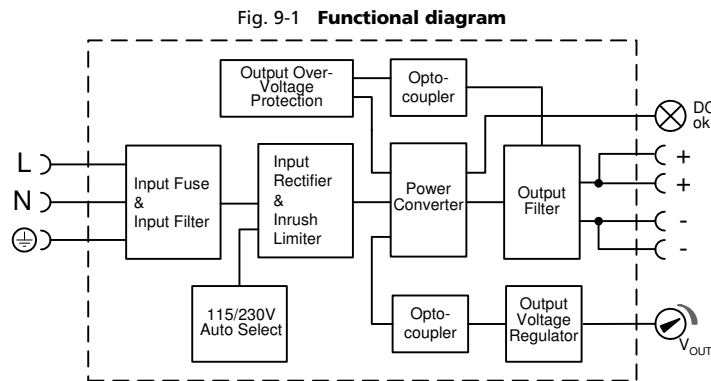

Fig. 8-4 Losses vs. input voltage at 24V, 5A, typ.





### 9. FUNCTIONAL DIAGRAM



### 10. FRONT SIDE AND USER ELEMENTS

Fig. 10-1 **Front side**

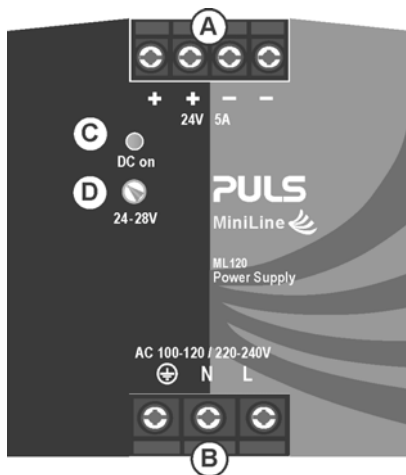

#### **A Output Terminals**

Screw terminals  
Dual terminals for the negative and positive pole.  
Both poles are equal  
+ Positive output  
- Negative (return) output

#### **B Input Terminals**

Screw terminals  
L Phase (Line) input  
N Neutral conductor input  
⊕ PE (Protective Earth) input

#### **C DC-on LED (green)**

On, when the voltage on the output terminals is > 20V (±4%)

#### **D Output voltage potentiometer**

Single turn potentiometer  
Turn to set the output voltage. Factory set: 24.5V

### 11. TERMINALS AND WIRING

All terminals are easy to access when mounted on the panel. Input and output terminals are separated from each other (input below, output above) to help in error-free wiring.

	Input	Output
<b>Type</b>	Screw terminals	Screw terminals
Solid wire	0.5-6mm <sup>2</sup>	0.5-6mm <sup>2</sup>
Stranded wire	0.5-4mm <sup>2</sup>	0.5-4mm <sup>2</sup>
American Wire Gauge	20-10 AWG	20-10 AWG
Max. wire diameter	2.8mm including ferrules	2.8mm including ferrules
Wire stripping length	7mm / 0.275inch	7mm / 0.275inch
Recommended tightening torque	1Nm, 9lb.in	1Nm, 9lb.in
Screw driver	3.5mm slotted or Philips No 2	3.5mm slotted or Philips No 2

#### Instructions:

- Use appropriate copper cables that are designed for minimum operating temperatures of:
  - 60°C for ambient up to 45°C,
  - 75°C for ambient up to 60°C and
  - 90°C for ambient up to 70°C minimum.
- Follow national installation codes and installation regulations!
- Ensure that all strands of a stranded wire enter the terminal connection!
- Do not use the unit without PE connection.
- Screws of unused terminal compartments should be securely tightened.
- Ferrules are allowed.

#### Daisy chaining:

Daisy chaining (jumping from one power supply output to the next) is allowed as long as the average output current through one terminal pin does not exceed 25A. If the current is higher, use a separate distribution terminal block as shown in Fig. 11-2.

**Fig. 11-1 Daisy chaining of outputs**

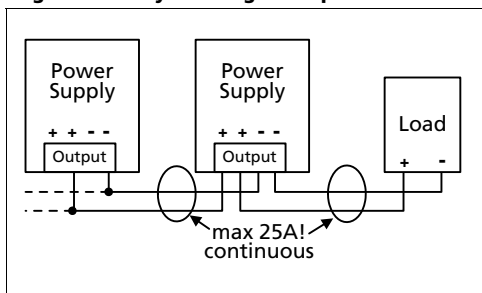

**Fig. 11-2 Using distribution terminals**

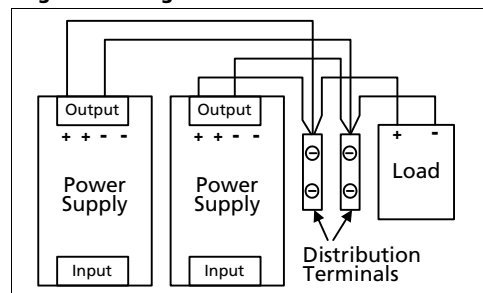

## 12. LIFETIME EXPECTANCY AND MTBF

The power supply is extremely reliable and use only the highest quality materials. The number of critical components such as electrolytic capacitors has been reduced.

	AC 100V	AC 120V	AC 230V	
Lifetime expectancy <sup>*)</sup>	38 000h	45 000h	58 000h	at 24V, 5A and 40°C
	117 000h	120 000h	146 000h <sup>*)</sup>	at 24V, 2.5A and 40°C
	107 000h	126 000h	164 000h <sup>*)</sup>	at 24V, 5A and 25°C
MTBF <sup>**) SN 29500, IEC 61709</sup>	T.B.D.	T.B.D.	T.B.D.	at 24V, 5A and 40°C
	T.B.D.	T.B.D.	T.B.D.	at 24V, 5A and 25°C
MTBF <sup>**) MIL HDBK 217F</sup>	T.B.D.	T.B.D.	T.B.D.	at 24V, 5A, 40°C; Ground Benign GB40
	T.B.D.	T.B.D.	T.B.D.	at 24V, 5A, 25°C; Ground Benign GB25
	T.B.D.	T.B.D.	T.B.D.	at 24V, 5A, 40°C; Ground Fixed GF40
	T.B.D.	T.B.D.	T.B.D.	at 24V, 5A, 25°C; Ground Fixed GF25

<sup>\*)</sup> The **Lifetime expectancy** shown in the table indicates the minimum operating hours (service life) and is determined by the lifetime expectancy of the built-in electrolytic capacitors. Lifetime expectancy is specified in operational hours and is calculated according to the capacitor's manufacturer specification. The manufacturer of the electrolytic capacitors only guarantees a maximum life of up to 15 years (131 400h). Any number exceeding this value is a calculated theoretical lifetime which can be used to compare devices.

<sup>\*\*) MTBF stands for **M**ean **T**ime **B**etween **F**ailure, which is calculated according to statistical device failures, and indicates reliability of a device. It is the statistical representation of the likelihood of a device to fail and does not necessarily represent the life of a product. A MTBF figure of e.g. 1 000 000h means that statistically one device will fail every 100 hours if 10 000 devices are installed in the field. However, it can not be determined if the failed device has been running for 50 000h or only for 100h.</sup>

### 13. EMC

The power supply is suitable for applications in industrial environment as well as in residential, commercial and light industry environment without any restrictions. A detailed EMC report is available on request.

<b>EMC Immunity</b>		Generic standards: EN 61000-6-1 and EN 61000-6-2		
Electrostatic discharge	EN 61000-4-2	Contact discharge	8kV	Criterion A
		Air discharge	8kV	Criterion A
Electromagnetic RF field	EN 61000-4-3	80MHz-2.7GHz	10V/m	Criterion A
Fast transients (Burst)	EN 61000-4-4	Input lines	4kV	Criterion A
		Output lines	2kV	Criterion A
		DC-OK Signal (coupling clamp)	2kV	Criterion A
Surge voltage on input	EN 61000-4-5	L → N	2kV	Criterion A
		N → PE, L → PE	4kV	Criterion A
Surge voltage on output	EN 61000-4-5	+ → -	1kV	Criterion A
		+ → PE, - → PE	2kV	Criterion A
Conducted disturbance	EN 61000-4-6	0.15-80MHz	10V	Criterion A
Mains voltage dips	EN 61000-4-11	0% of 100Vac	0Vac, 20ms	Criterion A
		40% of 100Vac	40Vac, 200ms	Criterion C
		70% of 100Vac	70Vac, 500ms	Criterion A
		0% of 200Vac	0Vac, 20ms	Criterion A
		40% of 200Vac	80Vac, 200ms	Criterion A
70% of 200Vac	140Vac, 500ms	Criterion A		
Voltage interruptions	EN 61000-4-11		0Vac, 5000ms	Criterion C
Input voltage swells	PULS internal standard		300Vac, 500ms	Criterion A
Powerful transients	VDE 0160	over entire load range	750V, 1.3ms	Criterion A

#### Criteria:

- A:** Power supply shows normal operation behavior within the defined limits.
- B:** The power supply operates continuously during and after the test. During the test minor temporary impairments may occur, which will be corrected by the power supply itself.
- C:** Temporary loss of function is possible. Power supply may shut-down and restarts by itself. No damage or hazards for the power supply will occur.

<b>EMC Emission</b>		Generic standards: EN 61000-6-3 and EN 61000-6-4	
Conducted emission input lines	EN 55011, EN 55022, FCC Part 15, CISPR 11, CISPR 22		Class B
Conducted emission output lines	IEC/CISPR 16-1-2, IEC/CISPR 16-2-1		limits for DC power port acc. EN 61000-6-3 not fulfilled **)
Radiated emission	EN 55011, EN 55022, CISPR 11, CISPR 22		Class B
Harmonic input current	EN 61000-3-2		Class A fulfilled
Voltage fluctuations, flicker*)	EN 61000-3-3		Fulfilled

This device complies with FCC Part 15 rules.

Operation is subjected to following two conditions: (1) this device may not cause harmful interference, and (2) this device must accept any interference received, including interference that may cause undesired operation.

\*) tested with constant current loads, non pulsing

\*\*) Restrictions apply for applications in residential, commercial and light-industrial environments, where local DC power networks according to EN 61000-6-3 are involved. No restrictions for all kinds of industrial applications.

#### Switching frequency

Converter frequency	variable, typ. 100kHz, min. 60kHz, max. 260kHz	Input voltage and output load dependent
---------------------	--	---

### 14. ENVIRONMENT

Operational temperature <sup>*)</sup>	-10°C to +70°C (14°F to 158°F)	reduce output power according Fig. 14-1
Storage temperature	-40°C to +85°C (-40°F to 185°F)	for storage and transportation
Output de-rating	3W/°C	60-70°C (140°F to 158°F)
Humidity <sup>**)</sup>	5 to 95% r.H.	IEC 60068-2-30
Vibration sinusoidal	2-17.8Hz: ±1.6mm; 17.8-500Hz: 2g 2 hours / axis	IEC 60068-2-6
Shock	15g 6ms, 10g 11ms 3 bumps / direction, 18 bumps in total	IEC 60068-2-27
Altitude	0 to 2000m (0 to 6 560ft) 2000 to 6000m (6 560 to 20 000ft)	without any restrictions reduce output power or ambient temperature see Fig. 14-2 IEC 62103, EN 50178, overvoltage category II
Altitude de-rating	7.5W/ 1000m or 5°C/1000m	> 2000m (6500ft), see Fig. 14-2
Over-voltage category	III II	IEC 62103, EN 50178, altitudes up to 2000m altitudes from 2000m to 6000m
Degree of pollution	2	IEC 62103, EN 50178, not conductive
LABS compatibility	The unit does not release any silicone or other LABS-critical substances and is suitable for use in paint shops.	

\*) Operational temperature is the same as the ambient temperature and is defined as the air temperature 2cm below the unit.

\*\*\*) Do not energize while condensation is present

Fig. 14-1 Output power vs. ambient temp.

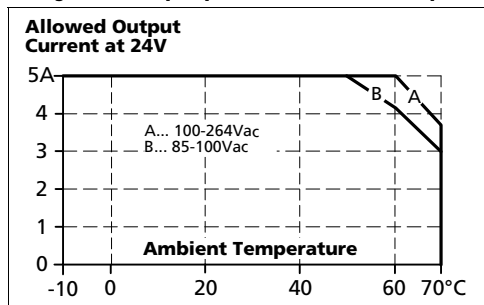
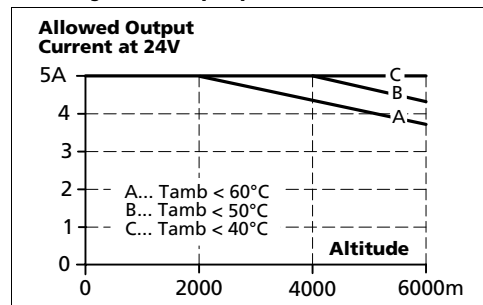

Fig. 14-2 Output power vs. altitude



### 15. PROTECTION FEATURES

Output protection	Electronically protected against overload, no-load and short-circuits <sup>*)</sup>	
Output over-voltage protection	typ. 31Vdc max. 32Vdc	In case of an internal power supply fault, a redundant circuit limits the maximum output voltage. The output shuts down and automatically attempts to restart.
Output over-current protection	electronically limited	see Fig. 5-1
Degree of protection	IP 20	EN/IEC 60529
Penetration protection	> 2.5mm in diameter	e.g. screws, small parts
Over-temperature protection	not included	
Input transient protection	MOV	Metal Oxide Varistor
Internal input fuse	T3.15A H.B.C.	not user replaceable

\*) In case of a protection event, audible noise may occur.

## 16. SAFETY FEATURES

Input / output separation	SELV <sup>*)</sup> PELV <sup>*)</sup>	IEC/EN 60950-1 IEC/EN 60204-1, EN 50178, IEC 62103, IEC 60364-4-41
Class of protection	I	PE (Protective Earth) connection required
Isolation resistance	> 5MΩ	Input to output, 500Vdc
Touch current (leakage current)	typ. 0.36mA / 0.60mA typ. 0.51mA / 0.85mA typ. 0.56mA / 1.17mA < 0.45mA / 0.72mA < 0.64mA / 1.02mA < 0.75mA / 1.45mA	100Vac, 50Hz, TN-,TT-mains / IT-mains 120Vac, 60Hz, TN-,TT-mains / IT-mains 230Vac, 50Hz, TN-,TT-mains / IT-mains 110Vac, 50Hz, TN-,TT-mains / IT-mains 132Vac, 60Hz, TN-,TT-mains / IT-mains 264Vac, 50Hz, TN-,TT-mains / IT-mains

\*) Double or reinforced insulation

## 17. DIELECTRIC STRENGTH

The output voltage is floating and has no ohmic connection to the ground. Type and factory tests are conducted by the manufacturer. Field tests may be conducted in the field using the appropriate test equipment which applies the voltage with a slow ramp (2s up and 2s down). Connect all phase-terminals together as well as all output poles before conducting the test. When testing, set the cut-off current settings to the value in the table below.

Fig. 17-1 Dielectric strength

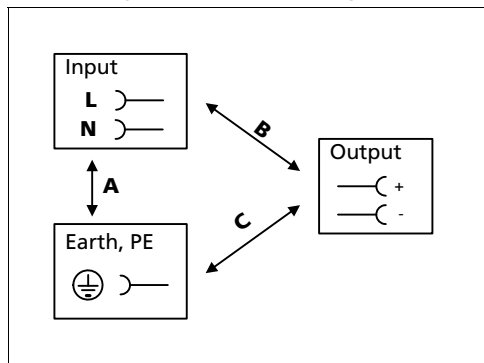

		<b>A</b>	<b>B</b>	<b>C</b>
Type test	60s	2500Vac	3500Vac	1000Vac
Factory test	5s	2500Vac	2500Vac	500Vac
Field test	5s	2000Vac	2000Vac	500Vac
Cut-off current setting		> 10mA	> 10mA	> 20mA

To fulfill the PELV requirements according to EN 60204-1 § 6.4.1, we recommend that either the + pole, the - pole or any other part of the output circuit shall be connected to the protective earth system. This helps to avoid situations in which a load starts unexpectedly or can not be switched off when unnoticed earth faults occur.

## 18. APPROVALS

EC Declaration of Conformity



The CE mark indicates conformance with the  
 - EMC directive 2004/108/EC,  
 - Low-voltage directive (LVD) 2006/95/EC and the  
 - RoHS directive 2011/65/EC.

IEC 60950-1 2<sup>nd</sup> Edition pending



CB Scheme, Information Technology Equipment

UL 508 pending



Listed for the use as Industrial Control Equipment;  
 E-File: E198865

UL 60950-1 2<sup>nd</sup> Edition pending



Recognized for the use as Information Technology Equipment, Level 3 in U.S.A. (UL 60950-1) and Canada (C22.2 No. 60950-1);  
 E-File: E137006

Marine pending



Marine and offshore applications environmental category: C, EMC2  
 GL (Germanischer Lloyd) classified

GOST P pending



Certificate of Conformity for Russia and other GUS countries

## 19. FULFILLED STANDARDS

EN 61558-2-17	Safety of Power Transformers
EN/IEC 60204-1	Safety of Electrical Equipment of Machines
EN 50178, IEC 62103	Electronic Equipment in Power Installations
EN/IEC 61131-2	Programmable Controllers

## 20. PHYSICAL DIMENSIONS AND WEIGHT

Weight	360g / 0.8lb
DIN-Rail	Use 35mm DIN-rails according to EN 60715 or EN 50022 with a height of 7.5 or 15mm. The DIN-rail height must be added to the unit depth (103mm) to calculate the total required installation depth.
Installation Clearances	See chapter 2

Fig. 20-1 Front view

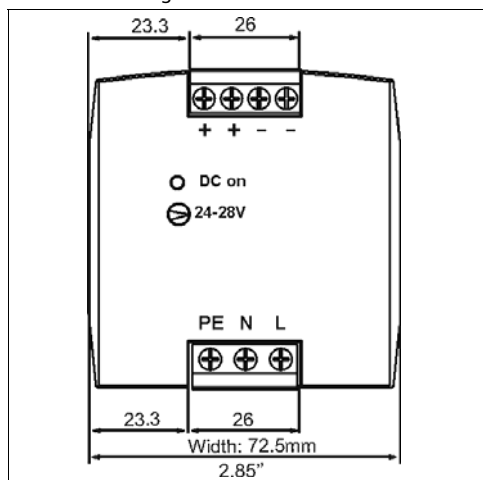
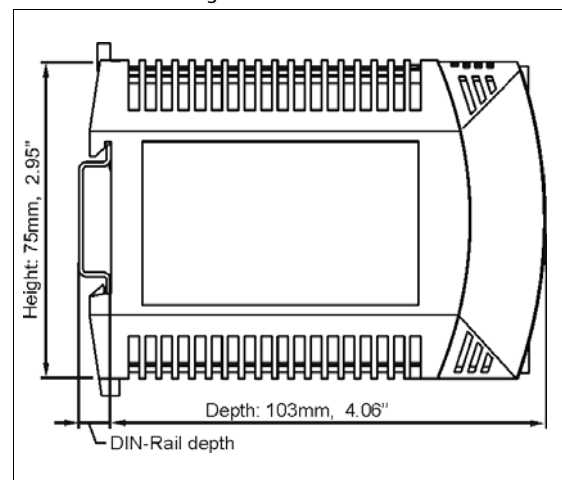

Fig. 20-2 Side view





## 21. ACCESSORY

### 21.1. REDUNDANCY MODULES



The MLY10.241 is a dual redundancy module, which has two diodes with a common cathode included. It can be used for various purposes. The most popular application is to configure highly reliable and true redundant power supply systems. Another interesting application is the separation of sensitive loads from non-sensitive loads. This avoids the distortion of the power quality for the sensitive loads

which can cause controller failures.

The YRM2.DIODE is a redundancy module in a DIMENSION housing which monitors both input voltages and reports failures with an alarm signal.

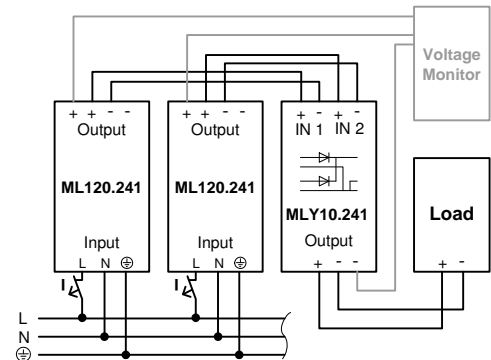

## 22. APPLICATION NOTES

### 22.1. PEAK CURRENT CAPABILITY

The power supply can deliver peak currents up to several milliseconds.

This helps to start current demanding loads. Loads such as solenoids, contactors and pneumatic modules often have a steady state coil and a pick-up coil. The inrush current demand of the pick-up coil is several times higher than the steady-state current and usually exceeds the nominal output current. The same situation applies when starting a capacitive load.

The peak current capability also ensures the safe operation of subsequent circuit breakers of load circuits. The load branches are often individually protected with circuit breakers or fuses. In case of a short or an overload in one branch circuit, the fuse or circuit breaker need a certain amount of over-current to open in a timely manner. This avoids voltage loss in adjacent circuits.

The extra current (peak current) is supplied by the power converter and the built-in large sized output capacitors of the power supply. The capacitors get discharged during such an event, which causes a voltage dip on the output. The following two examples show typical voltage dips:

Fig. 22-1 **Peak loading with 2x the nominal current for 50ms, typ.**

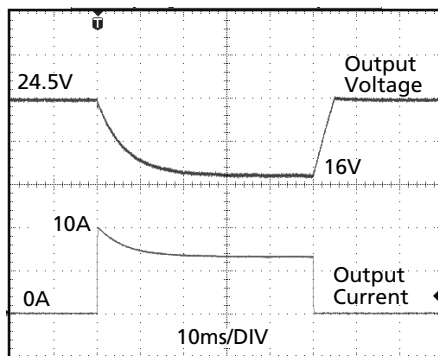

Peak load 10A (resistive load) for 50ms  
Output voltage dips from 24V to 16V.

Fig. 22-2 **Peak loading with 5x the nominal current for 5ms, typ.**

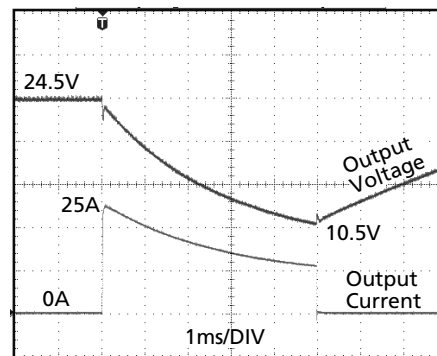

Peak load 25A (resistive load) for 5ms  
Output voltage dips from 24V to 10.5V.

Peak current voltage dips	typ.	from 24V to 16V	at 10A for 50ms, resistive load
	typ.	from 24V to 16V	at 25A for 2ms, resistive load
	typ.	from 24V to 10.5V	at 25A for 5ms, resistive load

### 22.2. BACK-FEEDING LOADS

Loads such as decelerating motors and inductors can feed voltage back to the power supply. This feature is also called return voltage immunity or resistance against Back- E.M.F. (Electro Magnetic Force).

This power supply is resistant and does not show malfunctioning when a load feeds back voltage to the power supply. It does not matter whether the power supply is on or off.

The maximum allowed feed-back-voltage is 35Vdc. The absorbing energy can be calculated according to the built-in large sized output capacitor which is specified in chapter 5.

### 22.3. CHARGING OF BATTERIES

The power supply can be used to charge lead-acid or maintenance free batteries. (Two 12V batteries in series)

#### Instructions for charging batteries (float charging):

- Ensure that the ambient temperature of the power supply is below 45°C.
- Set output voltage (measured at no load and at the battery end of the cable) very precisely to the end-of-charge voltage.

End-of-charge voltage	27.8V	27.5V	27.15V	26.8V
Battery temperature	10°C	20°C	30°C	40°C

- Use a 6A or 8A circuit breaker (or blocking diode) between the power supply and the battery.
- Ensure that the output current of the power supply is below the allowed charging current of the battery.
- Use only matched batteries when putting 12V types in series.
- The return current to the power supply (battery discharge current) is typical 11mA when the power supply is switched off (except in case a blocking diode is utilized).

### 22.4. EXTERNAL INPUT PROTECTION

The unit is tested and approved for branch circuits up to 20A. An external protection is only required, if the supplying branch has an ampacity greater than this. Check also local codes and local requirements. In some countries local regulations might apply.

If an external fuse is necessary or utilized, minimum requirements need to be considered to avoid nuisance tripping of the circuit breaker. A minimum value of 10A B- or 6A C-Characteristic breaker should be used.

### 22.5. PARALLEL USE TO INCREASE OUTPUT POWER

All MiniLine power supplies with 24V output voltage can be paralleled to increase the output power. The output voltage shall be adjusted to the same value ( $\pm 100\text{mV}$ ) with the same load conditions on all units, or the units can be left with the factory settings. The ML120.241 has no feature included which balances the load current between the power supplies. Usually the power supply with the higher adjusted output voltage draws current until it goes into current limitation. This means no harm to the MiniLine power supplies as long as the ambient temperature stays below 45°C.

If more than three units are connected in parallel, a fuse or circuit breaker with a rating of 8A or 10A is required on each output. Alternatively, a diode or redundancy module can also be utilized.

Keep an installation clearance of 15mm (left / right) between two power supplies and avoid installing the power supplies on top of each other. Do not use power supplies in parallel in mounting orientations other than the standard mounting orientation (input terminals on bottom and output terminals on the top of the unit) or in any other condition where a derating of the output current is required.

Be aware that leakage current, EMI, inrush current, harmonics will increase when using multiple power supplies.

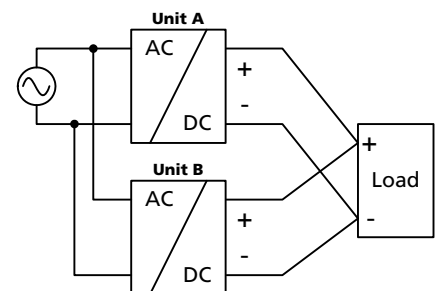

### 22.6. PARALLEL USE FOR REDUNDANCY

Power supplies can be paralleled for redundancy to gain higher system availability. Redundant systems require a certain amount of extra power to support the load in case one power supply unit fails. The simplest way is to put two power supplies in parallel. This is called a 1+1 redundancy. In case one power supply unit fails, the other one is automatically able to support the load current without any interruption. Redundant systems for a higher power demand are usually built in a N+1 method. E.g. five power supplies, each rated for 5A are paralleled to build a 20A redundant system.

**Please note:** This simple way to build a redundant system does not cover failures such as an internal short circuit in the secondary side of the power supply. In such a case, the defect unit becomes a load for the other power supplies and the output voltage can not be maintained any more. This can only be avoided by utilizing decoupling diodes which are included in the redundancy module MLY10.241 or YRM2.DIODE.

Recommendations for building redundant power systems:

- Use separate input fuses for each power supply.
- Use separate mains systems for each power supply whenever it is possible.
- Monitor the individual power supply units. A monitoring circuit is included in the DIMENSION redundancy module YRM2.DIODE, which can also be used as a redundancy module for the ML120.241 units.
- 1+1 Redundancy is allowed up to an ambient temperature of 60°C.  
N+1 Redundancy is allowed up to an ambient temperature of 45°C.
- It is desirable to set the output voltages of all units to the same value ( $\pm 100\text{mV}$ ) or leave it at the factory setting.

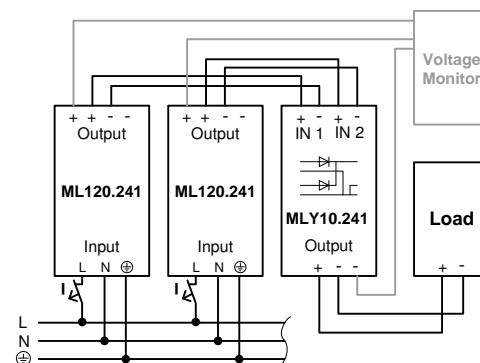

### 22.7. INDUCTIVE AND CAPACITIVE LOADS

The unit is designed to supply any type of load, including unlimited capacitive and inductive loads.

### 22.8. SERIES OPERATION

Power supplies of the exact same type can be connected in series for higher output voltages. It is possible to connect as many units in series as needed, providing the sum of the output voltage does not exceed 150Vdc. Voltages with a potential above 60Vdc are not SELV any more and can be dangerous. Such voltages must be installed with a protection against touching.

Earthing of the output is required when the sum of the output voltage is above 60Vdc.

Avoid return voltage (e.g. from a decelerating motor or battery) which is applied to the output terminals.

Keep an installation clearance of 15mm (left / right) between two power supplies and avoid installing the power supplies on top of each other. Do not use power supplies in series in mounting orientations other than the standard mounting orientation (input terminals on the bottom and output terminals on top of the unit).

Be aware that leakage current, EMI, inrush current, harmonics will increase when using multiple power supplies.

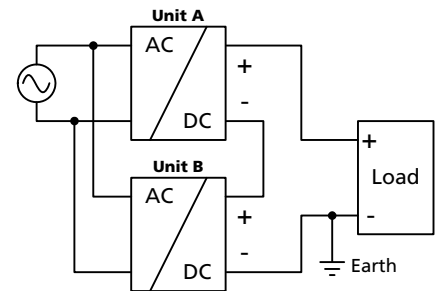

### 22.9. OPERATION ON TWO PHASES

The power supply can also be used on two-phases of a three-phase-system. A phase-to-phase connection is allowed as long as the supplying voltage is below 240V<sup>+10%</sup>. Use a fuse or a circuit breaker to protect the N input. The N input is not internally protected and is in this case connected to a hot wire. Appropriate fuses or circuit breakers are specified in section 22.4 "External Input Protection".

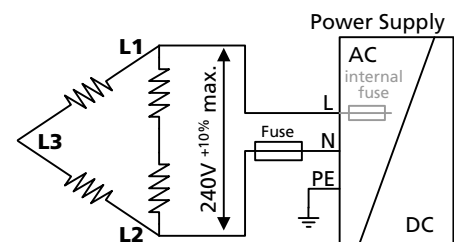

### 22.10. USE IN A TIGHTLY SEALED ENCLOSURE

When the power supply is installed in a tightly sealed enclosure, the temperature inside the enclosure will be higher than outside. In such situations, the inside temperature defines the ambient temperature for the power supply.

The following measurement results can be used as a reference to estimate the temperature rise inside the enclosure.

The power supply is placed in the middle of the box; no other heat producing items are inside the box.

Enclosure: Rittal Type IP66 Box PK 9510 100, plastic, 130x130x99mm  
 Input: 230Vac

#### Case A:

Load: 24V, 5A; load is placed outside the box  
 Temperature inside the box: 62.4°C (in the middle of the right side of the power supply with a distance of 1cm)  
 Temperature outside the box: 23.5°C  
 Temperature rise: 38.2K

#### Case B:

Load: 24V, 4A; (=80%) load is placed outside the box  
 Temperature inside the box: 54.8°C (in the middle of the right side of the power supply with a distance of 1cm)  
 Temperature outside the box: 22.8°C  
 Temperature rise: 32.0K

### 22.11. MOUNTING ORIENTATIONS

Mounting orientations other than input terminals on the bottom and output on the top require a reduction in continuous output power or a limitation in the maximum allowed ambient temperature. The amount of reduction influences the lifetime expectancy of the power supply. Therefore, two different derating curves for continuous operation can be found below:

**Curve A1** Recommended output current.

**Curve A2** Max allowed output current (results in approximately half the lifetime expectancy of A1).

Fig. 22-3  
**Mounting Orientation A**  
(Standard orientation)

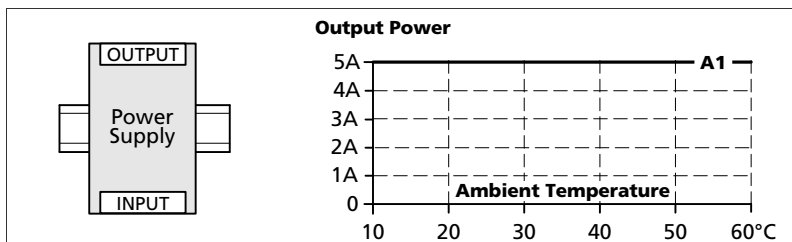

Fig. 22-4  
**Mounting Orientation B**  
(Upside down)

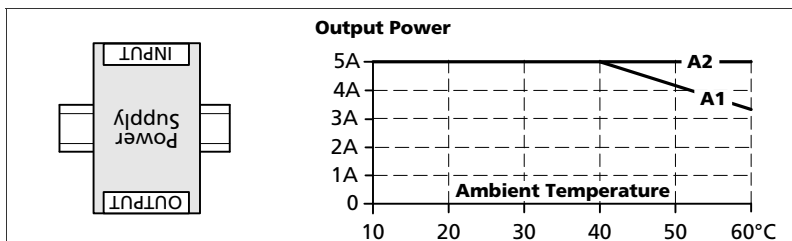

Fig. 22-5  
**Mounting Orientation C**  
(Table-top mounting)

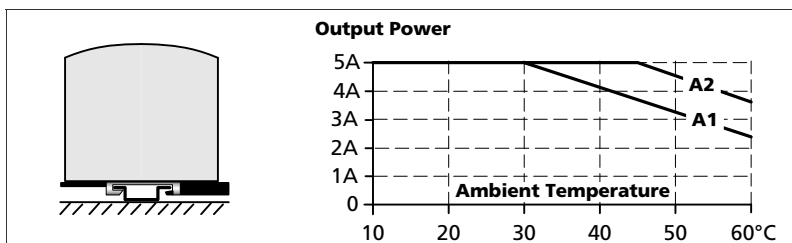

Fig. 22-6  
**Mounting Orientation D**  
(Horizontal cw)

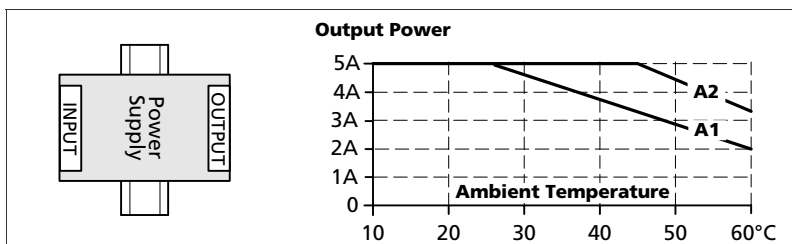

Fig. 22-7  
**Mounting Orientation E**  
(Horizontal ccw)

