

Speed controller direct piping/elbow

SC3R Series

● Port size: M5, Rc1/8 to Rc1/2

JIS symbol



(Meter-out)



(Meter-in)



Specifications

Item	SC3R-M5	SC3R-6	SC3R-8	SC3R-10	SC3R-15	
Working fluid	Compressed air					
Max. working pressure MPa	1.0 (≈150 psi, 10 bar)					
Min. working pressure MPa	0.05 (≈7.3 psi, 0.5 bar)					
Proof pressure MPa	1.5 (≈220 psi, 15 bar)					
Fluid temperature °C	5 (41°F) to 60 (140°F) (no freezing) *2					
Ambient temperature °C	0 (32°F) to 60 (140°F) (no freezing)					
Port size	M5	Rc1/8	Rc1/4	Rc3/8	Rc1/2	
Weight g	14	40	70	110	190	
Cylinder bore size mm	ø6 to ø16	ø15 to ø32	ø20 to ø50	ø32 to ø75	ø40 to ø110	
Dial value (needle position)	11	14	14	14	16	
Free flow	Flow rate l/min(ANR)	80	270	500	1100	1600
	Eff. X-sectional area mm ²	1.2	4.0	7.5	16	24
Controlled flow	Flow rate l/min(ANR)	47	240	470	1100	1600
	Eff. X-sectional area mm ²	0.7	3.6	7.0	15	24

*1: Flow rate is the atmospheric pressure conversion at 0.5 MPa.

*2: Freezing may occur due to adiabatic expansion depending on the air quality (dew point).

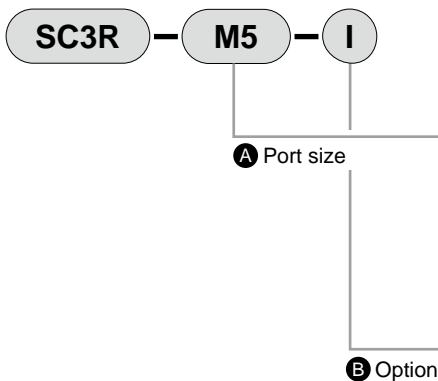

Code	Description
A Port size	
M5	M5×0.8
6	Rc1/8
8	Rc1/4
10	Rc3/8
15	Rc1/2
B Option	
I	Meter-in
Blank	Meter-out

Ozone-proof specifications (Ending Page 9)

SC3R — — **P11**

Clean-room specifications (Catalog No. CB-033SA)

● Anti-dust generation structure for use in cleanrooms

SC3R — — **P7***

Flow characteristics

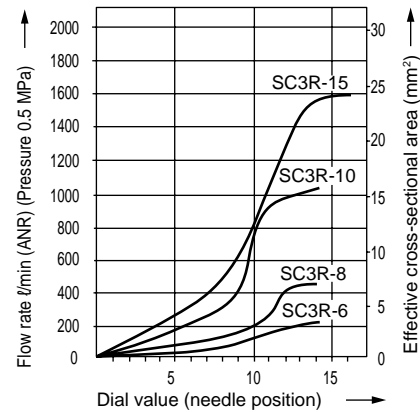
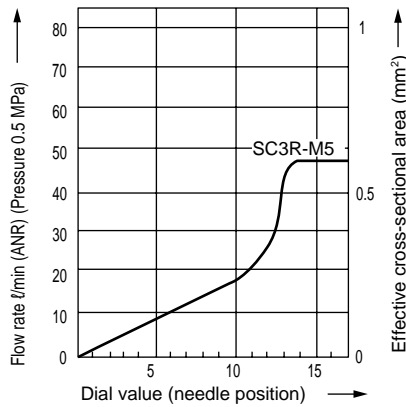

Internal structure and parts list

● SC3R-M5

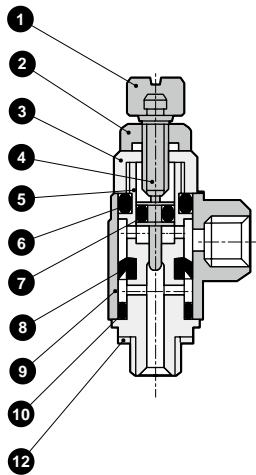

● SC3R-6 to 15

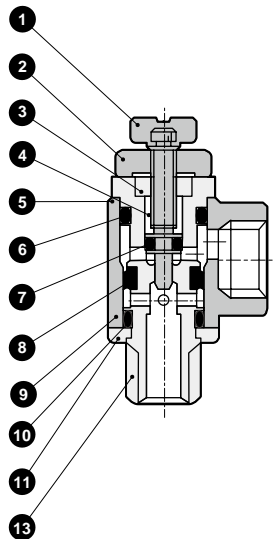

No.	Part name	Material
1	Knob	Copper alloy
2	Lock nut	Copper alloy
3	Gland nut	Copper alloy
4	Needle	Stainless steel
5	Rotary shaft	Copper alloy
6	O-ring	Nitrile rubber
7	O-ring	Nitrile rubber
8	Packing	Hydrogenated nitrile rubber
9	Rotor	Zinc die-casting (copper alloy)
10	O-ring	Nitrile rubber
11	Snap ring	Polybutylene terephthalate resin
12	M5 gasket	Nitrile rubber + steel
13	Sealant	Fluorinated resin

* (): SC3R-M5

* All the copper alloy parts have electroless nickel plating.

Dimensions



● SC3R-M5

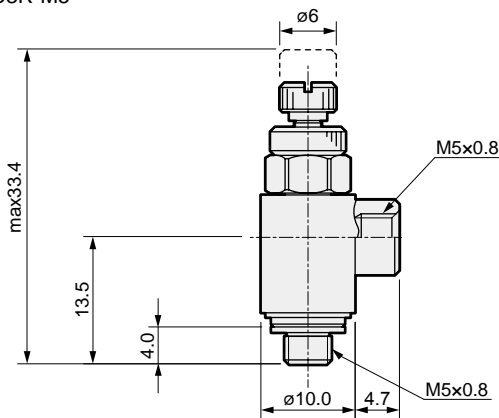

● SC3R-6 to 15

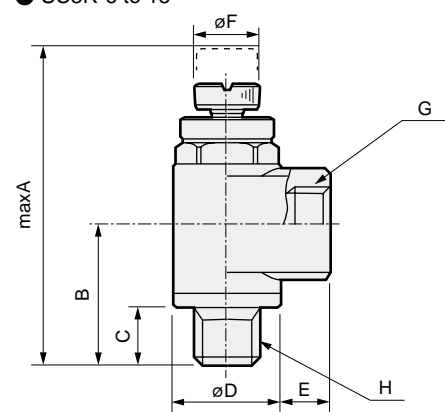

Model No.	A	B	C	D	E	F	G	H
SC3R-6	42.5	18.8	7.7	15.0	6.7	9	Rc1/8	R1/8
SC3R-8	51.2	23.2	10.7	19.0	9.4	12	Rc1/4	R1/4
SC3R-10	60.2	27.0	11.7	22.5	10.0	14	Rc3/8	R3/8
SC3R-15	66.7	30.0	14.7	27.0	13.7	16	Rc1/2	R1/2

- F.R.L.
- F.R.
- F (Filtr)
- R (Reg)
- L (Lub)
- Drain Separ
- Mech Press SW
- Res press exh valve
- SlowStart
- Anti-bac/Bac-remove Filtr
- Film Resist FR
- Oil-ProhR
- Med Press FR
- No Cu/ PTFE FRL
- Outdris FRL
- Adapter Joiner
- Press Gauge
- CompFRL
- LgFRL
- PreCsR
- VacF/R
- Clean FR
- ElecPneuR
- AirBoost
- Speed Ctrl
- Silncr
- CheckV/ other
- Fit/Tube
- Nozzle
- Air Unit
- PreCsCompn
- Electro Press SW
- ContactSW
- AirSens
- PresSW Cool
- Air Flo Sens/Ctrl
- WaterRISens
- TotAirSys (Total Air)
- TotAirSys (Gamma)
- Gas generator
- RefrDry
- DesiccDry
- HiPolymDry
- MainFiltr
- Dischrg etc
- Ending